

Instrukcja montażu w niszach ściennych i za szafkami

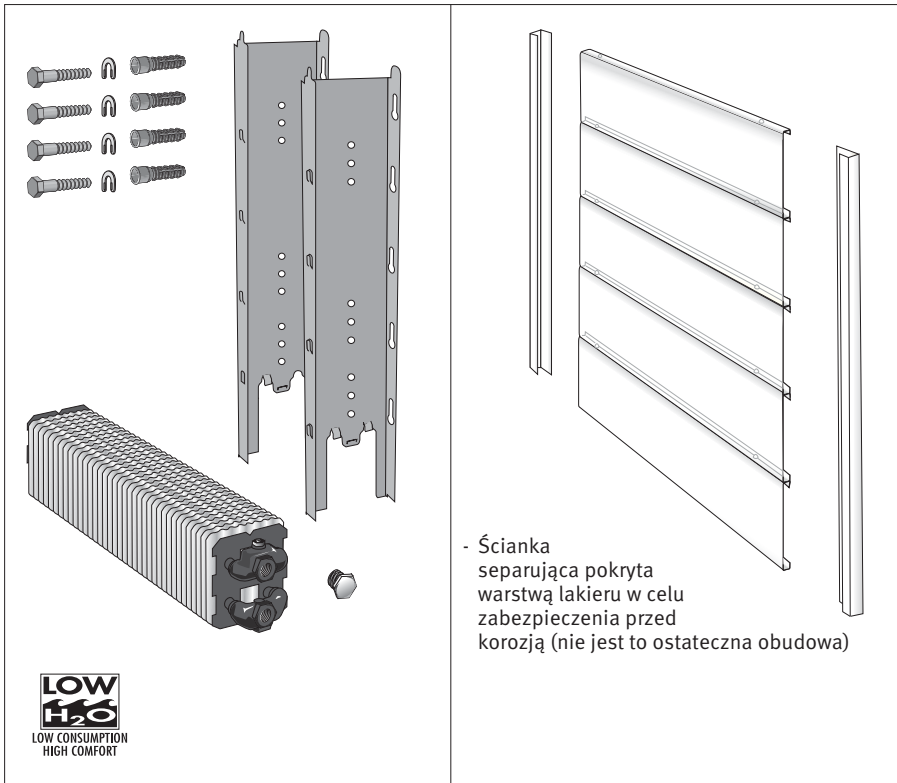

WYMIARY (w cm)

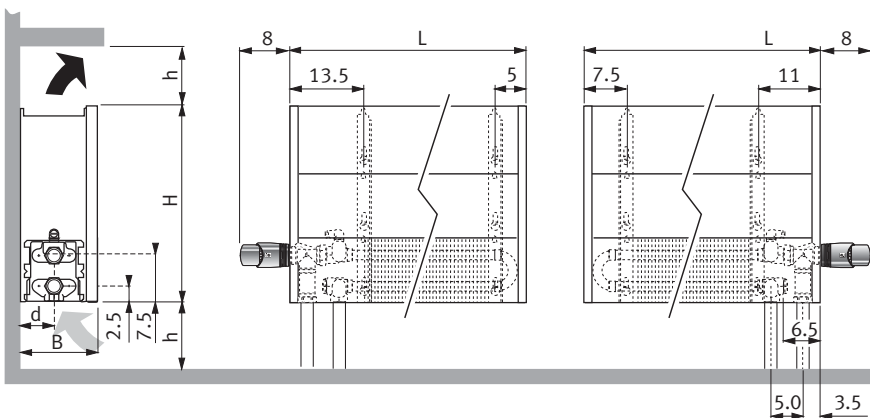

WYMIARY w cm			
Typ	B	d	h min*
10-11	11.8	5.3	10
15-16	16.8	7.8	12
20-21	21.8	10.3	15

* Mniejsze wymiary mogą ograniczyć wydajność grzejnika.

	L	H
040	140	020
050	160	030
060	180	040
070	200	050
080	220	060
090	240	070
100	260	090
110	280	
120	300	

OPCJA ZAWORY



OPCJA

Automatyczny odpowietrznik
do typów 10, 15 en 20.
Nie pasuje do obudowy o wysokości 20 cm.



5090.040506

Instalacja

Szafki powinny być zbudowane w sposób umożliwiający dostęp do wymiennika ciepła w celu corocznej konserwacji. W celu uniknięcia zanieczyszczenia wymiennika ciepła np. nieczystościami z blatu, kratkę należy zamontować nieco powyżej krawędzi szafki.

